

# ALP..F7D7 ALMP..F7D7



## TYPE



**T**ype ALP..F7D7 is a roller type freewheel, self-contained, sealed and bearing supported using two 160.. series bearings. Unit is not delivered oil lubricated.

This cover combination is mostly used as an overrunning or indexing clutch as shown overleaf. A keyway is machined on the outer race for the connection to the drive or driven member centered on its outside.

D7 cover is used to close the unit. It is equipped with two screws for oil filling, drain and level. The shaft seal is a V-ring type. Cover and seal have been designed to be oil proof with minimum drag torque.

## ALP..F7D7

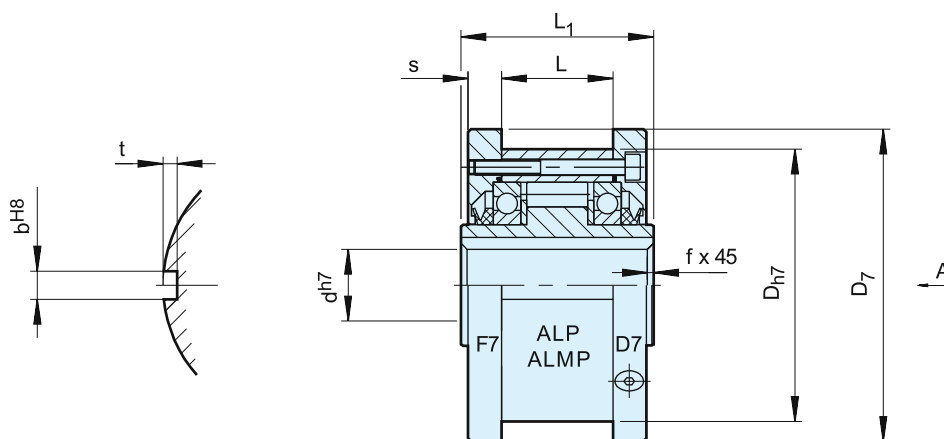

Type	Size	Overrunning speeds <sup>n</sup>											Weight	Drag torque
		$T_{KN}^{1)}$ [Nm]	$n_{imax}^{2)}$ [min <sup>-1</sup> ]	$n_{amax}^{3)}$ [min <sup>-1</sup> ]	$D_{h7}$ [mm]	$L_1$ [mm]	$D_7$ [mm]	$s$ [mm]	$L$ [mm]	$b^{H8}$ [mm]	$t$ [mm]	$f$ [mm]		
ALP..F7D7	12	55	2500	7200	62	42	70	10,4	20	4	2,4	0,5	1,0	11
	15	125	1900	6500	68	52	76	11,4	28	5	2,9	0,8	1,4	15
	20	181	1600	5600	75	57	84	10,9	34	6	3,5	0,8	1,9	18
	25	288	1400	4500	90	60	99	11,9	35	8	4,1	1	2,8	36
	30	500	1300	4100	100	68	109	11,9	43	8	4,1	1	3,7	45
	35	725	1100	3800	110	74	119	13,4	45	10	4,7	1	4,7	60
	40	1025	950	3400	125	86	135	15,4	53	12	4,9	1,5	7,1	84
	45	1125	900	3200	130	86	140	15,4	53	14	5,5	1,5	7,4	94
	50	2125	850	2800	150	92	160	12,9	64	14	5,5	1,5	10,4	128
	55	2625	720	2650	160	104	170	17,5	66	16	6,2	2	13,4	150
	60	3500	680	2450	170	114	182	16,5	78	18	6,8	2	15,9	160
	70	5750	580	2150	190	134	202	18	95	20	7,4	2,5	20,8	360
	80	8500	480	1900	210	144	222	20,5	100	22	8,5	2,5	27,1	360
	90	14500	380	1700	230	158	242	20	115	25	8,7	3	39,4	680
	100	20000	350	1450	270	182	282	28,5	120	28	9,9	3	66,4	880
	120	31250	250	1250	310	202	322	22,5	152	32	11,1	3	91,5	1200
	150	70000	180	980	400	246	412	31	180	36	12,3	4	187	1350
200	175000	120	750	520	326	540	40	240	45	15	5	430	4200	
250	287500	100	620	610	396	630	45	300	45	15	5	688	6500	
ALMP F7D7	25	388	1100	2800	90	60	99	11,9	35	8	4,1	1	2,9	41
	30	588	1000	2500	100	68	109	11,9	43	8	4,1	1	3,85	64
	35	838	900	2400	110	74	119	13,4	45	10	4,7	1	4,9	76

## NOTES

1)  $T_{max} = 2 \times T_{KN}$   
 » Refer to Selection page 10 to 13

2) Inner race overruns

3) Outer race overruns

Keyway to DIN 6885.1

When ordering, please specify direction of rotation seen from arrow „A“: „R“ Inner race overruns in clockwise direction, „L“ Inner race overruns in counterclockwise direction

» Refer to mounting and maintenance instructions page 16 to 19

## MOUNTING EXAMPLE

