

# DC

## TYPE



**T**ype DC is a sprag type freewheel cage without inner or outer races. It must be installed in a design providing races, bearing support for axial and radial loads, lubrication and sealing. The DC type version-N accepts all types of lubricants currently used in the power transmission equipment.

The sprag space tolerance must not be exceeded. Inner and outer races must both have a minimum plain width “e”, without any recess, to ensure the freewheel

functions correctly as shown on following pages.

Alternatively, races can be made in case hardened steel shafts, or housings, to the specification below. Surface hardness of the finished part should be HRC 60 to 62, for a depth of 0,6 mm minimum.

Core hardness to be HRC35 to 45. Surface roughness not to exceed 22CLA. Maximum taper between races: 0,007 mm for 25 mm width.

DC

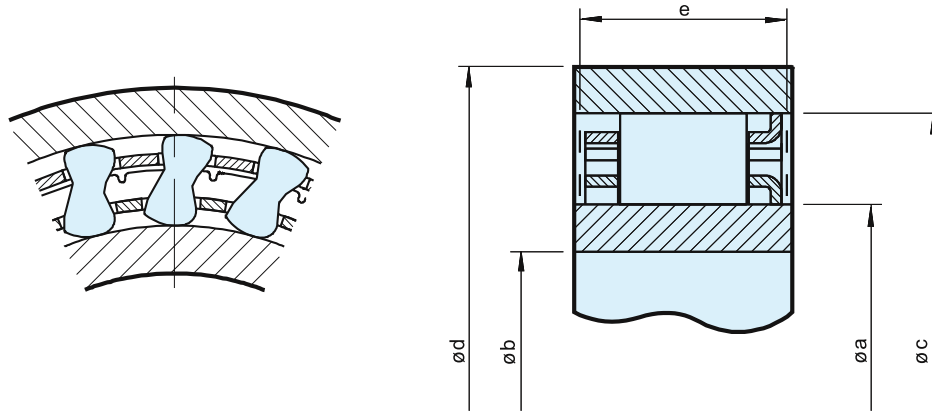

Size	Overrunning speeds			Sprag space		Number of dips	Number of sprags	Weight				
	$T_{KN}^{1)}$ [Nm]	$n_{imax}^{2)}$ [min <sup>-1</sup> ]	$n_{amax}^{3)}$ [min <sup>-1</sup> ]	$\varnothing a^{+0.008}$ $-0.005$ [mm]	$\varnothing c^{\pm 0.013}$ [mm]							
DC2222G-N	63	8600	4300	22.225	38.885	8.33 ±0.1	10.0	50	15	—	12	0.030
DC2776-N	119	6900	3400	27.762	44.422	8.33 ±0.1	13.5	58	18	—	14	0.055
DC3034-N	124	6300	3100	30.340	47.000	8.33 ±0.1	13.5	62	20	—	14	0.060
DC3175(3C)-N	159	6000	3000	31.750	48.410	8.33 ±0.1	13.5	63	21	3	16	0.060
DC3809A-N	275	5000	2500	38.092	54.752	8.33 ±0.1	16.0	71	25	—	18	0.085
DC4127(3C)-N	224	4600	2300	41.275	57.935	8.33 ±0.1	13.5	75	27	3	18	0.090
DC4445A-N	363	4300	2100	44.450	61.110	8.33 ±0.1	16.0	79	29	—	20	0.095
DC4972(4C)-N	306	3800	1900	49.721	66.381	8.33 ±0.1	13.5	86	33	4	22	0.100
DC5476A-N	525	3500	1700	54.765	71.425	8.33 ±0.1	16.0	92	36	—	24	0.110
DC5476A(4C)-N	525	3500	1700	54.765	71.425	8.33 ±0.1	16.0	92	36	4	24	0.130
DC5476B(4C)-N	769	3500	1700	54.765	71.425	8.33 ±0.1	21.0	92	36	4	24	0.180
DC5476C(4C)-N	990	3500	1700	54.765	71.425	8.33 ±0.1	25.4	92	36	4	24	0.200
DC5776A-N	604	3300	1600	57.760	74.420	8.33 ±0.1	16.0	98	38	—	26	0.110
DC6334B-N	806	3000	1500	63.340	80.000	8.33 ±0.1	21.0	104	42	—	26	0.175
DC7221(5C)-N	675	2600	1300	72.217	88.877	8.33 ±0.1	13.5	115	48	5	30	0.140
DC7221B-N	1279	2600	1300	72.217	88.877	8.33 ±0.1	21.0	115	48	—	30	0.185
DC7221B(5C)-N	1279	2600	1300	72.217	88.877	8.33 ±0.1	21.0	115	48	5	30	0.210
DC7969C(5C)-N	2038	2400	1200	79.698	96.358	8.33 ±0.1	25.4	124	53	5	34	0.280
DC8334C-N	2055	2300	1100	83.340	100.000	8.33 ±0.1	25.4	132	55	—	34	0.270
DC8729A-N	1250	2200	1100	87.290	103.960	8.33 ±0.1	16.0	134	58	—	34	0.165
DC10323A(5C)*-N	1612	1800	900	103.231**	119.891	8.33 ±0.1	16.0	155	68	5	40	0.205
DC12334C*-N	4800	1500	750	123.340**	140.000	8.33 ±0.1	25.4	184	80	—	50	0.400
DC12388C(11C)	4875	1500	750	123.881	142.880	9.50 ±0.1	25.4	186	80	11	44	0.400

## NOTES

1)  $T_{max} = 2 \times T_{KN}$

» Refer to Selection page 12 to 19

2) Inner race overruns

3) Outer race overruns

\*) The inner cage centering flange is on the opposite side

\*\*) Extension of tolerance to ± 0.013 permissible

Other dimensions on request

» Refer to mounting and maintenance instructions page 16 to 19

## MOUNTING EXAMPLES

