

Installation and Maintenance Instructions Freewheel Type FSO

To avoid premature failure of the freewheel or possible machine malfunction, installation of the freewheel should be carried out by suitably qualified personnel and according to the following instructions.

STIEBER will not accept liability in cases of non-compliance with these instructions!

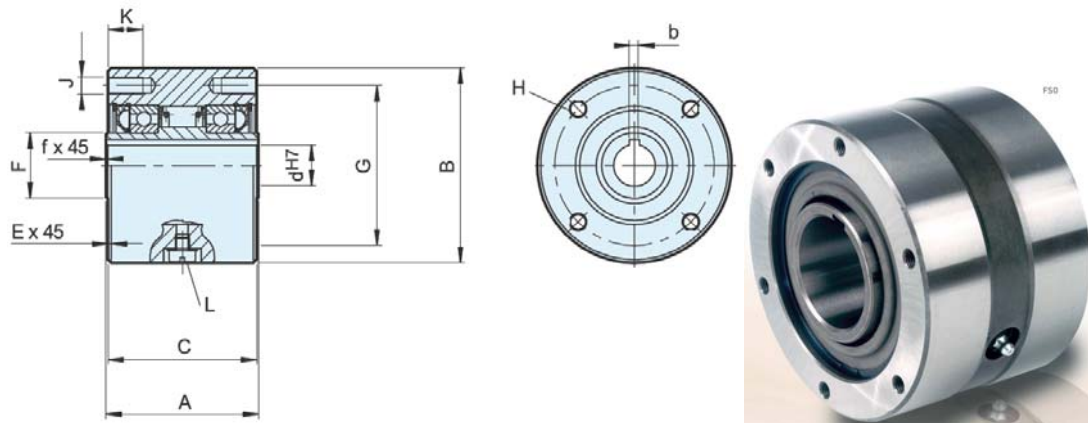

Type	Size	Overrunning speeds												Lubricant			Weight	Drag torque							
		FSD	FSD-GR	d ^{H7} -b _x h	d ^{H4}	A	B	C	E	F	G	H	J	K	L	f			FSD	FSD.GR	HPI				
		T _{KN} ¹⁾	n _{max} ²⁾	n _{max} ³⁾		min-max	-0,05																		
		[Nm]	[min ⁻¹]	[min ⁻¹]	[mm]	[mm]	[mm]	[mm]	[mm]	[mm]	[mm]	[mm]	[mm]	[mm]	[mm]	[mm]	[mm]	[mm]	[mm]	[mm]	[mm]	[mm]	[mm]	[mm]	[mm]
FSD FSD-GR HPI	300	379	3000/900	3600/900	15-5x5	12... 19	63,50	76,20	60,45	1,6	28,58	66,67	4	M8	13	M6	0,8	7	10	14	1,6	18			
	400	407	2800/850	3600/850	18-6x6	12... 22	69,85	88,90	68,07	1,6	30	73	4	M8	13	M6	0,8	10	20	20	2,7	27			
	500	1621	2500/800	3000/800	30-8x7	19... 33	88,90	107,95	85,73	1,6	45	92	4	M8	16	M6	1,5	22	35	35	4,8	31			
					40-12x8																				
	600	3105	2200/750	2400/750	45-14x9	24... 57	95,25	136,525	92,2	1,6	63,5	120,6	6	M8	16	M6	1,6	52	84	84	8,6	62			
					50-14x6																				
					50-14x9																				
	700	6900	1600/450	2000/450	60-18x11	48... 82	127,00	180,975	123,85	1,6	90	158,75	8*	M10*	20	M6	1,6	168	280	280	19	156			
					65-18x11																				
					70-20x12						101,6 ⁵⁾														

Description:

The main components of FSO freewheel units are: Outer race, inner race, a cage assembly with a number of individually spring energised sprags, two roller bearings and two shaft seals. Up to size 700 the freewheels are oil lubricated. Larger units are usually grease filled.

FSO units are based on imperial dimensions, but with metric mounting threads as standard.

FSO units may be installed with either the inner race or the outer race overrunning, subject to the limits specified in the table below.

Prior to Installation:

The units should be unpacked and installed in a clean dry working environment.

For units despatched 'dry', corrosion inhibitor should be removed using flushing oil prior to installation.

The inner race should be fitted to a shaft of h6 tolerance if the unit is supplied with a metric bore.

We recommend the following shaft tolerances when using imperial bores and shafts.

Bore Ø H7	Shaft fit
up to 2"	Clearance fit up to 0.05 mm clearance
greater than 2" to 4"	Clearance fit up to 0.06 mm clearance
greater than 4" to 7"	Clearance fit up to 0.075 mm clearance

The mounting register for the outer race should be to H7 or G7 tolerance.

The freewheeling direction should be checked prior to installation.

If reversal of the freewheeling direction is required, turn the freewheel through 180°.

We recommend the following tightening torque for the fixing bolts, based on bolts to grade 10.9.

Size	Bolts	Tightening Torque [Nm]
300	M8	34
400	M8	34
500	M8	34
600	M8	34
700	M10	66
750	M12	115
800	M12	115
900	M16	280
1027	M16	280

Installation:

The clutch should be installed as an assembly.

The inner race should be pulled on to the shaft. The key should be the full length of the hub.

Apply axial load to the inner race only.

Use a circlip or retainer plate for axial location of the freewheel.

After Installation:

After installation, ensure smooth rotation of the unit in the freewheeling direction.

Ensure the unit contains the correct volume of lubricant prior to use.

The expected drag torque when overrunning is about 1/1000 of the freewheel nominal driving torque.

Dismantling:

To remove the unit follow the installation instructions in reverse order.
Apart from the replacement of oil seals we do not recommend the unit be dismantled.

Technical data FSO freewheels:

Size	Max. Torque [Nm]	Overrunning Speed [rpm]	
		Inner Race	Outer Race
300	760	3000	900
400	810	2800	850
500	3250	2500	800
600	3100	2200	750
700	13800	1600	450
750	19500	1800	650
800	36000	1500	525
900	49000	1350	500
1027	73000	1100	375

Lubrication: Units up to size 750

FSO units up to size 750 are usually delivered oil lubricated using oil to ISO-VG 22.
If specified for enclosed use -gearboxes etc - unit will be despatched dry without seals.
Depending on application details, it may be necessary to change the oil used.
Please refer to the lubricants recommendation below.

Oil level check:

- Position one plug at 12 o'clock and one at 6 o'clock position.
- Remove the plug at the 9 (or 3) o'clock position and the 12 o'clock position.
- Fill until oil runs from the lateral port.

If the unit is mounted on a non-horizontal shaft please refer to your local STIEBER stockist.

Oil change:

- Position one plug at 6 o'clock and one at 12 o'clock.
- Remove top and bottom plug, allowing unit to drain before replacing the plugs and refilling as described above.

The plug seals should be replaced if showing signs of leakage.

Lubricant volume FSO units:

Size	Lubrication	Volume [ml]
300	oil	7
400	oil	10
500	oil	22
600	oil	50
700	oil	170
750	grease	220
800	grease	220
900	grease	530
1027	grease	650

Maintenance:

- The lubricating oil should be changed after approximately 10 hours operation. Further oil changes should be made after every 2000 hours.
In arduous applications - high temperature / dusty conditions- change oil every 1000 operating hours.
- With ambient temperatures above 80°C, check lubrication regularly.
- For operating temperatures below -20°C and above 100°C contact the technical department of your lubricant suppliers.
- For indexing applications, oil types with a kinematic viscosity of about 10mm²/s at the normal operating temperature are recommended.

Lubricants with slip additives such as graphite, Molykote or similar agents should be avoided.

Lubrication: Units size 750 and larger

FSO 750 units and larger are usually supplied grease filled.

These units should be re-lubricated every 3 months, in arduous conditions - high temperature / dusty conditions - every month.

- The proper grease volume is achieved when grease starts seeping from the seals whilst grease is pumped in.

Recommended Lubricants

	Ambient temperature				Grease
	-40°C to- 15°C	-15°C to +15°C	+15°C to +30°C	+30°C to +50°C	
	Operating temperature				
	-20°C to +20°C	+10°C to +50°C	+40°C to +70°C	+50°C to +85°C	
	Oil				
ISO - VG DIN 51519	10	22	46	100	
ARAL	SUMOROL CM10	SUMOROL CM22	MOTANOL HK46	DEGOL CL100T	ARALUB HL2
BP	ENERGOL CS10	ENERGOL CS22	ENERGOL CS46	ENERGOL RC100	ENERGREASE LS2
DEA	ASTRON HL10	ASTRON HL22	ASTRON HL46	ASTRON HL100	GLISSANDO 20
ESSO	NUTO H10 SPINESSO 10	NUTO H22 SPINESSO 22	NUTO H46 TERESSO 46	NUTO H100	BEACON 2
FUCHS	RENOLIN MR3	RENOLIN DTA22	RENOLIN DTA46	RENOLIN MR30	RENOLIT LZR2
KLÜBER	CRUCOLAN 10	CRUCOLAN 22	CRUCOLAN 46	CRUCOLAN 100	POLYLUB WH2
MOBIL	VELOCITE No6	VELOCITE No10	VACTRA MEDIUM VG46	VACTRA HEAVY VG100	MOBILUX 2
SHELL	MORLINA 10	MORLINA 22	MORLINA 46	MORLINA 100	ALVANIA G2
TOTAL	AZZOLA ZS10	AZZOLA ZS22	AZZOLA ZS46	AZZOLA ZS100	MULTIS 2

Alternatively we strongly recommend the use of multigrade oils SAE 10W-40 at working temperature between 0° and +80 ° C.

The ambient temperature is to be taken as a guide line. The operating temperature is determinant for the choice of the viscosity.

Corrosion inhibitor: Rivolta KSP

Time of protection: 6 to 12 months

Recommendation: Prior to use, remove corrosion inhibitor using flushing oil.