

## Centrifugally Lift Off Sprags Freewheels

# RIZ..G2G3 RIZ..G3G4



### TYPE



Types RIZ..G2G3/G3G4 are centrifugal lift off sprag type freewheels with the inner race rotating. Only the inner race is designed for freewheeling.

They are self-contained units designed for backstop applications. The overrunning speed must not be less than the minimum specified in the table. This must be considered if using a variable speed drive. The torque bolt must be fitted into a slot on a fixed part of the

machine. The radial clearance should be 1–3 % of the bolt diameter. The torque arm and bearings must not be axially loaded.

They are a type RIZ, (↪ see page 82) equipped with G type covers featuring grease pockets and contact free seals. When ordered complete, the unit is delivered grease lubricated, ready for either horizontal or vertical installation.

# Centrifugally Lift Off Sprags Freewheels

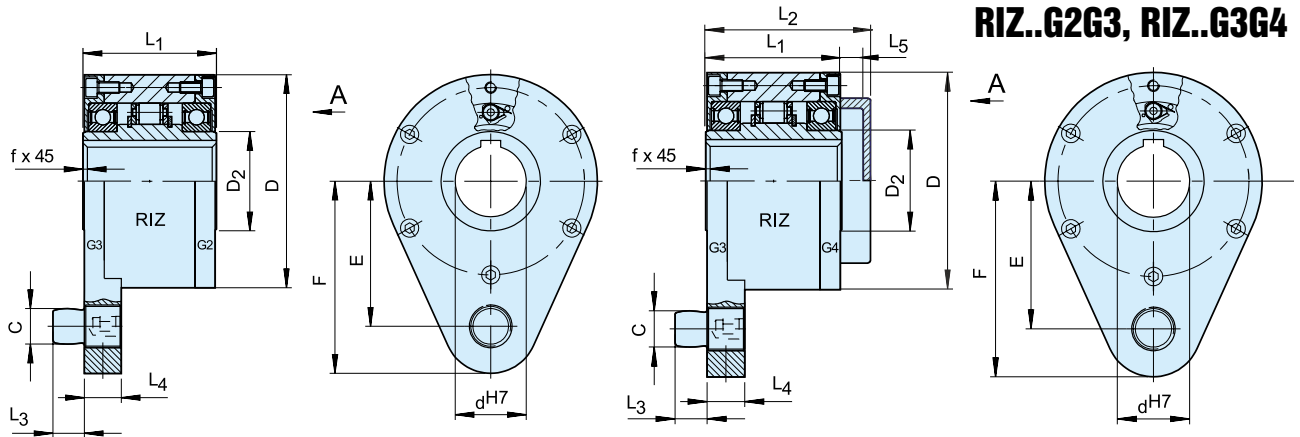

RIZ...G2G3

RIZ...G3G4

Type	Size	Speeds					D	D <sub>2</sub>	C	L <sub>1</sub>	L <sub>2</sub>	L <sub>3</sub>	L <sub>4</sub>	F	E	L <sub>5</sub>	f	Weight
		T <sub>KN</sub> <sup>1)</sup> [Nm]	n <sub>imin</sub> <sup>2)</sup> [min <sup>-1</sup> ]	n <sub>imax</sub> <sup>3)</sup> [min <sup>-1</sup> ]	D <sub>2</sub>	C												
RIZ..G2G3 RIZ..G3G4	30	375	700	9000	100	45	16	68	88	14	18	92	68	15	1,0	4,5		
	35	550	670	8500	110	50	20	74	96	18	25	102	76	17	1,0	5,6		
	40	800	630	7500	125	55	20	86	109	18	25	112	85	18	1,5	8,5		
	45	912	610	6700	130	60	25	86	109	22	25	120	90	18	1,5	8,9		
	50	1400	560	6000	150	70	25	94	116	22	25	135	102	18	1,5	12,8		
	60	2350	510	5300	170	80	32	114	139	25	30	145	112	20	2,0	19,3		
	70	3050	470	4000	190	90	38	134	168	30	35	175	135	26	2,5	23,5		
	80	5800	375	4000	210	105	38	144	178	30	35	185	145	26	2,5	32		
	90	8700	350	3000	230	120	50	158	192	40	45	205	155	26	3,0	47,2		
	100	16000	340	2400	270	140	50	182	217	40	45	230	180	26	3,0	76		
130	23000	320	2400	310	160	68	212	250	55	60	268	205	28	3,0	110			

## NOTES

1)  $T_{max} = 2 \times T_{KN}$   
 » Refer to Selection page 7 to 11

2) This minimum allowable overrunning speed  $n_{imi}$  should not be reduced under continuous operation. Possible reduction of this minimum speed on request.

3) Inner race overruns  
 Keyway to DIN 6885.1

When ordering, please specify direction of rotation seen from arrow „A“: „R“ Inner race overruns in clockwise direction, „L“ Inner race overruns in counterclockwise direction

» Refer to mounting and maintenance instructions page 12 to 13

## MOUNTING EXAMPLE

