

# RIZ..ELG2



## TYPE



**T**ype RIZ..ELG2 is a centrifugal lift off sprag type freewheel when the inner race is overrunning. Only this race is designed for freewheeling. It is a self-contained unit designed for overrunning clutch applications.

Typically used in crawl drives where the overrunning speed is high, but the drive speed is low and does not exceed the maximum driving speed specified in the table. It is a type RIZ (» see page 80 for further information) equipped with an EL elastic coupling and a cover G2.

The EL type is a high performance coupling used to damp torsional vibrations and to accept misalignment without excess bearing load.

The inner race must overrun and will be connected to the driven machine shaft. When ordered complete, the unit is delivered grease lubricated, ready for either horizontal or vertical installation. The torques given in the table are determined by the freewheel capacity.

## RIZ..ELG2

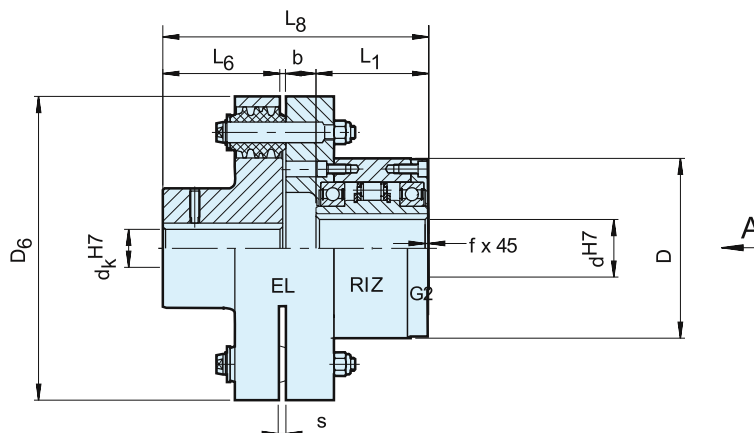

| Type      | Size | EL | $T_{KN}$<br>(Nm) | Speeds                                 |  |  | $d_k^{H7}$<br>(mm) | D<br>(mm) | $L_1$<br>(mm) | $D_6$<br>(mm) | $L_6$<br>(mm) | $L_8$<br>(mm) | b<br>(mm) | s<br>(mm) | f<br>(mm) | Weight<br>(kg) |
|-----------|------|----|------------------|--|--|--|--------------------|-----------|---------------|---------------|---------------|---------------|-----------|-----------|-----------|----------------|
|           |      |    |                  | $n_{max}^{1)}$<br>(min <sup>-1</sup> ) | $n_{min}^{2)}$<br>(min <sup>-1</sup> ) | $n_{max}^{3)}$<br>(min <sup>-1</sup> ) |                    |           |               |               |               |               |           |           |           |                |
| RIZ..ELG2 | 30   | 5  | 375              | 350                                    | 780                                    | 9000                                   | 20...55            | 100       | 68            | 160           | 60            | 147,5         | 19,5      | 2         | 1         | 11             |
|           | 35   | 6  | 550              | 320                                    | 740                                    | 8500                                   | 25...75            | 110       | 74            | 190           | 75            | 166,5         | 17,5      | 2         | 1         | 17             |
|           | 40   | 6  | 800              | 315                                    | 720                                    | 7500                                   | 25...75            | 125       | 86            | 190           | 75            | 176,5         | 15,5      | 2         | 1,5       | 19             |
|           | 45   | 6  | 912              | 285                                    | 665                                    | 6600                                   | 25...75            | 130       | 86            | 190           | 75            | 176,5         | 15,5      | 2         | 1,5       | 19             |
|           | 50   | 7  | 1400             | 265                                    | 610                                    | 6000                                   | 30...85            | 150       | 94            | 225           | 90            | 208,5         | 24,5      | 2,5       | 1,5       | 31             |
|           | 60   | 8  | 2350             | 200                                    | 490                                    | 5300                                   | 35...100           | 170       | 114           | 270           | 100           | 244           | 30        | 3         | 2         | 49             |
|           | 70   | 10 | 3050             | 210                                    | 480                                    | 4100                                   | 45...120           | 190       | 134           | 340           | 140           | 312,5         | 38,5      | 3         | 2,5       | 90             |
|           | 80   | 11 | 4500             | 190                                    | 450                                    | 3600                                   | 55...145           | 210       | 144           | 380           | 160           | 340           | 36        | 3         | 2,5       | 107            |
|           | 90   | 12 | 5600             | 180                                    | 420                                    | 2700                                   | 65...165           | 230       | 158           | 440           | 180           | 388           | 50        | 3,5       | 3         | 170            |
|           | 100  | 14 | 10500            | 200                                    | 455                                    | 2700                                   | 75...170           | 270       | 182           | 500           | 200           | 422,5         | 40,5      | 3,5       | 3         | 230            |
|           | 130  | 16 | 15750            | 180                                    | 415                                    | 2400                                   | 85...180           | 310       | 212           | 560           | 220           | 482           | 50        | 4         | 3         | 330            |

## NOTES

- 1) Inner race overruns  
This maximum allowable torque transmission speed  $n_{max}$  must not be exceeded when transmitting torque
- 2) This minimum allowable overrunning speed  $n_{min}$  should not be reduced under continuous operation.  
Possible reduction of this minimum speed on request
- 3) Inner race overruns  
Keyway to DIN 6885.1

When ordering, please specify  $d_k$  bore diameter and direction of rotation seen from arrow „A“: „R“ Inner race overruns in clockwise direction, „L“ Inner race overruns in counterclockwise direction

» Refer to mounting and maintenance instructions page 16 to 19

## MOUNTING EXAMPLE

