

型式 (TYPE) : SFS (DIN 69051 FORM B)

高速靜音型
High-Speed Ball Screw

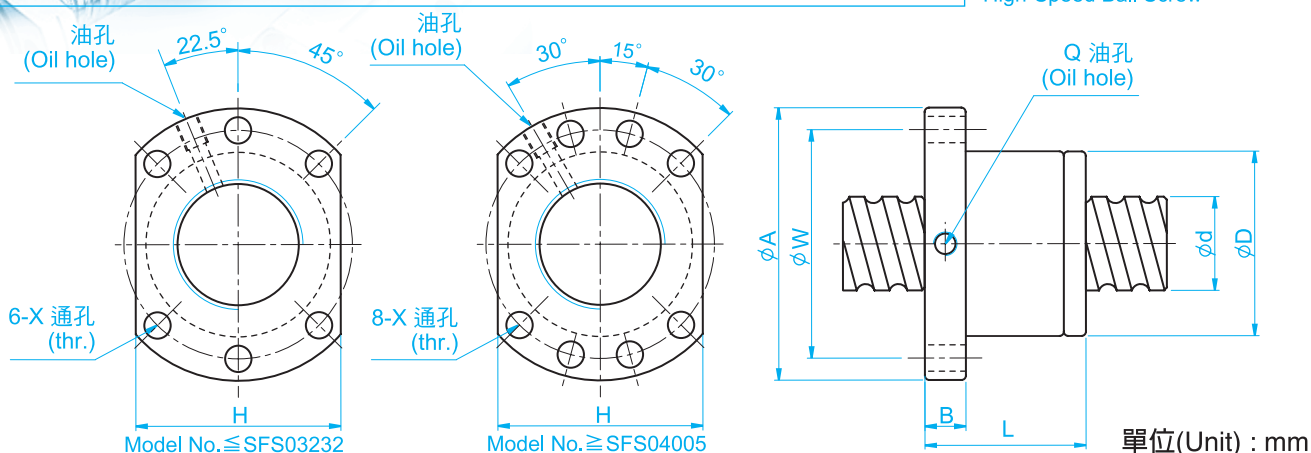

Model No. \leq SFS03232

Model No. \geq SFS04005

單位(Unit) : mm

l: 導程 Lead Da: 珠徑 Ball Dia. n: 珠圈數 Number of Circuits K: 剛性 Stiffness (Kgf/ μ m)
Ca: 動額定負荷 Basic Dynamic Rating Load (Kgf) Coa: 靜額定負荷 Basic Static Rating Load (Kgf)

型號 Model No.	滾珠螺桿、螺帽之基準數據 Dimensions														
	d	l	Da	D	A	B	L	W	H	X	Q	n	Ca	Coa	K
SFS01205-2.8	12	5	2.5	24	40	10	31	32	30	4.5		2.8x1	661	1316	19
SFS01210-2.8		10	2.5	24	40	10	48.5	32	30	4.5		2.8x1	642	1287	19
SFS01605-3.8	15	5	2.778	28	48	10	38	38	40	5.5	M6	3.8x1	1112	2507	30
SFS01610-2.8		10	2.778	28	48	10	47	38	40	5.5	M6	2.8x1	839	1821	23
SFS01616-1.8		16	2.778	28	48	10	45	38	40	5.5	M6	1.8x1	552	1137	14
SFS01616-2.8		16	2.778	28	48	10	61	38	40	5.5	M6	2.8x1	808	1769	22
SFS01620-1.8	20	20	2.778	28	48	10	57	38	40	5.5	M6	1.8x1	554	1170	14
SFS02005-3.8		5	3.175	36	58	10	40	47	44	6.6	M6	3.8x1	1484	3681	37
SFS02006-4.8	20	6	3.175	36	58	10	50	47	44	6.6	M6	4.8x1	1811	4644	47
SFS02008-4.8		8	3.175	36	58	10	60	47	44	6.6	M6	4.8x1	1863	4861	50
SFS02010-3.8		10	3.175	36	58	10	60	47	44	6.6	M6	3.8x1	1516	3833	40
SFS02020-1.8		20	3.175	36	58	10	57	47	44	6.6	M6	1.8x1	764	1758	19
SFS02020-2.8	25	20	3.175	36	58	10	77	47	44	6.6	M6	2.8x1	1118	2734	29
SFS02505-3.8		5	3.175	40	62	10	40	51	48	6.6	M6	3.8x1	1650	4658	43
SFS02506-4.8		6	3.175	40	62	10	50	51	48	6.6	M6	4.8x1	2015	5879	55
SFS02508-4.8		8	3.175	40	62	10	60	51	48	6.6	M6	4.8x1	2009	5867	56
SFS02510-3.8	31	10	3.175	40	62	12	62	51	48	6.6	M6	3.8x1	1638	4633	45
SFS02525-1.8		25	3.175	40	62	12	70	51	48	6.6	M6	1.8x1	843	2199	22
SFS02525-2.8		25	3.175	40	62	12	95	51	48	6.6	M6	2.8x1	1232	3421	34
SFS03205-3.8		32	5	3.175	50	80	12	42	65	62	9	M6	3.8x1	1839	6026
SFS03206-4.8	6		3.175	50	80	12	51	65	62	9	M6	4.8x1	2247	7608	65
SFS03208-4.8	31	8	3.969	50	80	12	62	65	62	9	M6	4.8x1	3015	9181	68
SFS03210-3.8		10	3.969	50	80	13	62	65	62	9	M6	3.8x1	2460	7255	55
SFS03220-2.8		20	3.969	50	80	12	80	65	62	9	M6	2.8x1	1907	5482	43
SFS03232-1.8		32	3.969	50	80	13	84	65	62	9	M6	1.8x1	1257	3426	27
SFS03232-2.8	40	32	3.969	50	80	13	116	65	62	9	M6	2.8x1	1838	5329	42
SFS04005-3.8		5	3.175	63	93	15	45	78	70	9	M8	3.8x1	2018	7589	60
SFS04006-4.8		6	3.175	63	93	14	50	78	70	9	M6	4.8x1	2467	9583	77
SFS04008-4.8		8	3.969	63	93	14	61	78	70	9	M6	4.8x1	3327	11491	81
SFS04010-3.8	38	10	6.35	63	93	14	63	78	70	9	M8	3.8x1	5035	13943	67
SFS04020-2.8		20	6.35	63	93	14	82	78	70	9	M8	2.8x1	3959	10715	54
SFS04040-1.8		40	6.35	63	93	15	105	78	70	9	M8	1.8x1	2585	6648	34
SFS04040-2.8		40	6.35	63	93	15	145	78	70	9	M8	2.8x1	3780	10341	52
SFS05005-3.8	50	5	3.175	75	110	15	45	93	85	11	M8	3.8x1	2207	9542	68
SFS05010-3.8		10	6.35	75	110	18	68	93	85	11	M8	3.8x1	5638	17852	79
SFS05012-3.8		12	6.35	75	110	18	75	93	85	11	M8	3.8x1	5632	17836	81
SFS05020-3.8		48	20	6.35	75	110	18	108	93	85	11	M8	3.8x1	5749	18485
SFS05050-1.8	50		6.35	75	110	18	125	93	85	11	M8	1.8x1	2946	8749	42
SFS05050-2.8	61	50	6.35	75	110	18	175	93	85	11	M8	2.8x1	4308	13610	65
SFS06310-3.8		10	6.35	90	125	18	70	108	95	11	M8	3.8x1	6343	23308	94
SFS06316-3.8		16	6.35	90	125	18	95	108	95	11	M8	3.8x1	6327	23262	100
SFS06320-3.8		20	7.144	95	135	20	116	115	100	13.5	M8	3.8x1	7493	26424	105
SFS08010-3.8	77	10	6.35	105	145	20	70	125	110	13.5	M8	3.8x1	6980	29563	105
SFS08020-3.8		20	9.525	125	165	25	120	145	130	13.5	M8	3.8x1	12145	43598	128
SFS10020-3.8	96	20	12.7	150	202	30	124	176	155	17.5	M8	3.8x1	19633	71408	152

備註: 有標註 ★ 記號者可製作左螺紋 Note: with sign ★ can be produced in left helix